ANANDA

USERS GUIDE

D17 PC2



Content

1. About user guide.....	2
2. Appearance Size and materials.....	2
3. Function Summary.....	3
4. Normal Display area.....	5
5. Cautions.....	5
6. Installation.....	5
7. Standard Operation.....	6
7.1 Power on/off.....	6
7.2 Speed/Distance/Time Display.....	6
7.3 Headlight turn on/off.....	7
7.4 6km/h Walk system.....	8
7.5 PAS level adjustment.....	8
7.6 Battery Indicator	9
7.7 Automatic adjustment of display light brightness.....	10
7.8 Error code.....	10
7.9 USB charging.....	13
7.10 Bluetooth function.....	13
8. Display Parameter Setting.....	14
8.1 Backlight setting.....	14
8.2 Single trip distance clearance setting.....	15
8.3 Version viewing setting.....	16
8.4 USB communication setting.....	17
9. Wire layout.....	18
10. Display Printing code.....	18
11. FAQ.....	19

12. Quality Warranty And Coverage.....	19
13. Software Version.....	16

1. About user Guide

Dear users,





To ensure better performance of your e-bike, please read through the D17 PC2 display introduction carefully before using it. We will use the brief words to inform you of all the details (including hardware installation, setting and normal use of the display) when using our display. Meanwhile, the introduction will also help you solve possible confusion and barriers.

2. Appearance Size and materials

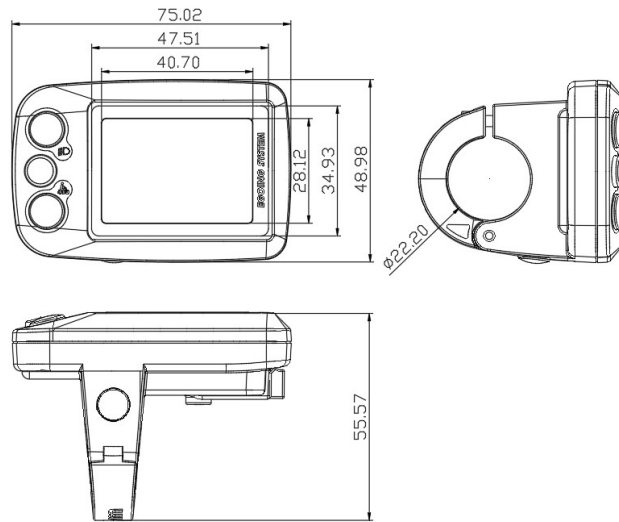
D17 PC2, the shell materials can work temperature scope: -20℃—+60℃, the shell material can ensure normal use and good mechanical performance of the products.

The Display Size drawing (Unit: mm)



D17 PC2 the button and display are integrated. In the follow-up instructions,  button replace with words "**switch**". "+" button replace with word "plug",  button replace with word "minus".  headlight button replace with words "**headlight**",  button replace with words "**walk**".  button replace with the words "**setting**".

3. Function Summary

D17 PC2 function overview:

- ① **Setting**
- ② **Bluetooth**
- ③ **Walk system**
- ④ **Headlight**
- ⑤ **Riding Mode**
- ⑥ **PAS level**
- ⑦ **Single trip time**
- ⑧ **Single trip distance**
- ⑨ **ODO**
- ⑩ **Remaining distance**
- ⑪ **Max speed**
- ⑫ **Average speed**
- ⑬ **Battery Indicator**
- ⑭ **Speed**

4. Normal Display area

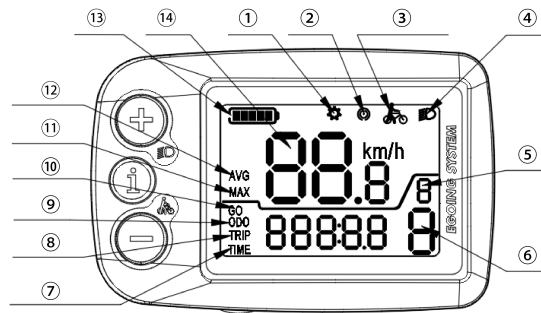

D17 PC2 display interface

5. Cautions



- Please handle it carefully.
- No connecting and disconnecting the display to the controller when it in working condition.
- Please return it to the factory immediately when failure.

6. Installation

Please install the display into the handlebar and connect it to the controller.

7. Standard Operation

7.1 Power on/off

Press the “” button (more than 2S), the controller will supply power to the display and start working. In the power on state, press “” button (more than 2S), the controller stops powering on the display. In the turn-off state, the display no longer uses the battery's power supply, and the meter's leakage current is less than 1uA.

7.2 Speed/Distance/time display

After the e-bike is turned on, the display shows the current speed and single trip distance by default. Hold “” button (less than 1s) to switch the display information. Switching at the following display interface : “average speed, single trip distance” display interface、 “max speed, single trip distance” display interface, “current speed, remaining distance ” display interface.



current speed, ODO

average speed、 single trip distance



max speed, single trip distance

7.3 Turn on/off the headlight

Auto mode: The display automatically controls the headlights on/off by sensing external light.

Manual mode: long press (more than 2.5s) "+" button to turn on headlight function, and long press "+" button again to turn off headlight function.

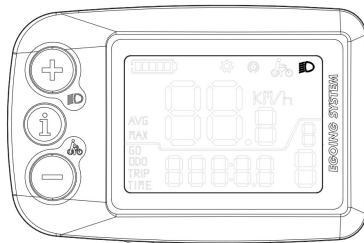

Turn on the headlight interface

7.4 6km/h Walk system

Long press (more than 2.5S) the "  " button, the walk indicator flashes, and then press the "-" button all the time to enter the walk mode.

Release the "-" button to disable the push and exit the push walk mode.

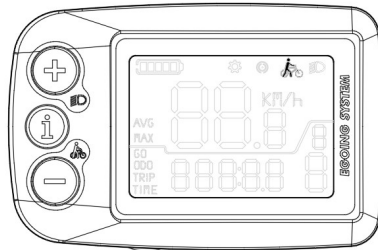

6km/h Walk system

7.5 PAS Level Adjustment

Press the "+" button (less than 1s) can increase the PAS Level. Press the "-" button (less than 1s) can reduce the PAS Level. Switch the PAS Level of the e-bike and change the output power of the motor. The default output power range of the display is 0-5 level, the 0 level is the lowest power, the 5 level is the highest power and default is 0.

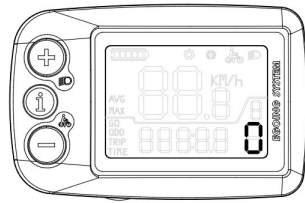

0 mode display interface

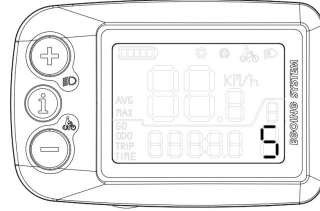

5 mode display interface

7.6 Battery Indicator

When the battery is at the highest capacity, all the five-segment battery indicator lights up. When the battery capacity is insufficient, it will be switched between a power indicator light and an empty segment, and the flashing state indicates that the battery is under voltage and needs to be charged immediately.

Percentage of battery capacity:

Battery Segment no.:	Battery/Percentage(Bafang/Ananda)
1	15%—29%
2	30%—44%
3	45%—59%
4	60%—84%
5	>=85%



Max battery display

Low battery display

Under voltage (Flashing)

7.7 Automatic adjustment of display light brightness

When the ambient brightness of the display changes, the display will automatically adjust the backlight brightness through the built-in light sensor. When the external environment is dimmed, the backlight brightness will be dimmed automatically. Meanwhile, the headlight will be turned on automatically. When the external environment is brightened, the backlight brightness will also be brightened automatically, and the headlight will be turned off.

To ensure the riders can read the display information accurately and comfortably.

7.8 Error code

When the e-bike electric control system fault occurs, the display will automatically enter to the error code interface. Only when the fault is cleared, the display can exit the error code interface. When the fault occurs, the e-bike will not be able to continue running.

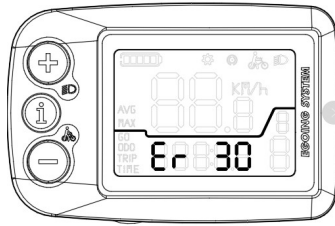

Error code interface

Error Code	Definition
01	Controller phase line overcurrent fault
02	Controller bus overcurrent fault
03	Controller HALL fault
04	Brake fault; throttle fault
05	Controller temperature fault
06	Motor temperature fault
07	Overload fault
08	Controller communication fault
09	Controller overvoltage, undervoltage
10	Other fault
30	Display communication fault
31-50	Controller New EN fault
31	MCU fault, reference voltage fault,

	calculated periodic fault
32	TE chip communication fault
33	3.3V power fault
34	Button fault
35	Button fault
36	Torque voltage fault
37	Brake fault, speed sensor fault, detector HALL fault
38	Temperature sensor fault
39	Reference sample overtime
40	Current feedback circuit fault
41	Drive voltage fault
42	Abnormal current fault
43	Motor phase fault, motor power on stop overtime fault
50	Torque voltage detects circuit fault

7.9 USB Charging

Plug in device that need USB charging when display power off. After that, turn on the display and charge the device. The charging sign "USB" on the display interface flashes 4 times, after 4 times stop flashing to avoid interfering with normal data display.

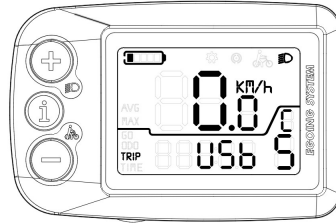

USB charging interface

7.10 Bluetooth Function

The Bluetooth indicator of display is shown as below. When display power on, the Bluetooth function is turned on by default.

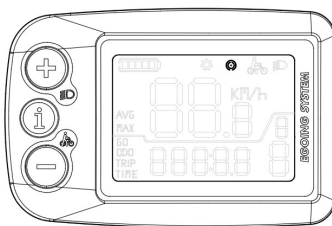

Bluetooth display interface

8. Parameter Setting

Press "+" and "-" (more than 2.5S) together to enter the parameter setting interface.

After entering the parameter setting interface, short press "+" (less than 1S) to switch the parameter item.

Press "-" key again (more than 2.5S) to enter the parameter setting item, and then press "-" key (more than 2.5S) to save the current parameters and exit the current setting item.

Press "+" and "-" together (more than 2.5S) to exit the parameter interface.

The specific setting items are described below:

8.1 Backlight parameter settings:

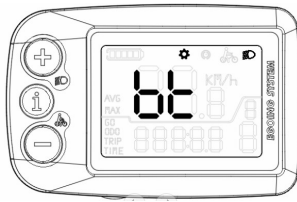

“Bt” stands for Backlight setting

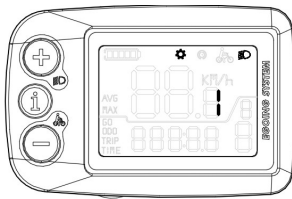

Min backlight setting

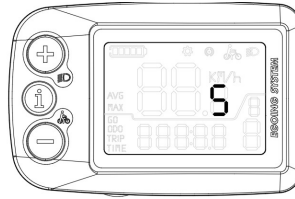

Max backlight setting

Long press "-" (more than 2.5S) to enter the setting page. The middle number is the backlight level. At this time, the minimum backlight level is 1 and the maximum backlight level is 5 (level from 0-5). Backlight always on.

Short press "+" and "-" (less than 1S) to adjust backlight level. Long press "-" (more than 2.5S) to exit the backlight parameter setting interface.

8.2 Single Trip Distance Clearance Setting:

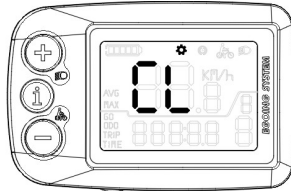

“CL” stands for trip distance clearance setting

Long press "-" (more than 2.5S) to enter the setting, long press "i" (more than 2.5S), the trip will become 0, and the trip is successfully cleared.

If not going to clearing, press and hold "-" (more than 2.5S) to exit the trip distance clearance setting interface.

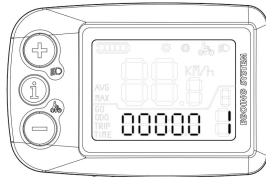

8.3 Version viewing setting

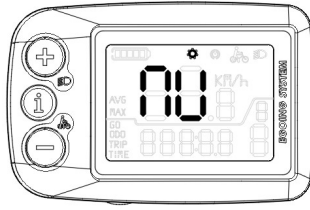

“NU” stands for version number

Long press "-" (more than 2.5S) to enter the setting, the display's software/hardware version number are automatically switched.

Short press "+" (less than 1S) to switch between the display version number and the controller version number. Long press "-"(greater than 2.5S) to exit this setting interface.



Controller Version



Hardware Version



Software Version

8.4 USB communication setting



"USB" stands for USB communication setting.

Long press "-" (more than 2.5S) to enter the setting. The default value is "N" flashing, which means that the USB communication is closed. "Y" flashing means USB communication is on. Short press "+"(less than 1S) to switch the USB communication status. (Note: When USB is used to charge external devices, the icon "N" will not flash, and the USB communication function cannot be turned on at the time. When the external device is disconnected, the icon "N" starts to flash, and the USB communication function can be turned on at the time).

When the USB communication is turned on and the parameter setting is exited, the "setting icon" on the normal display interface of the display will flash continuously.

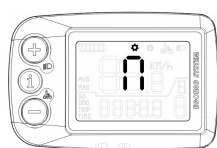

Turn off USB comm.

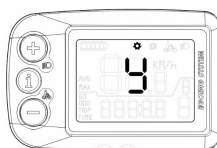

Turn on USB comm.

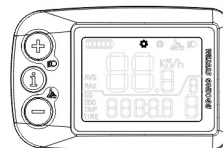

USB status

9. Wire Layout

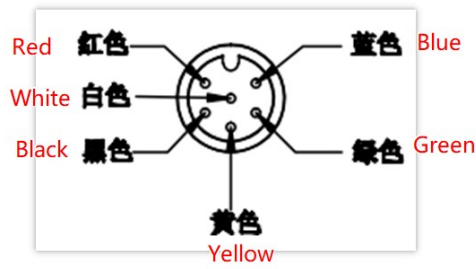

Connect with Controller

Wire connection definition

No.	Wire color	function
1	Red (VCC)	Power for display
2	Blue(K)	Key for controller
3	Black(GND)	GND
4	Green(CANH)	CAN H
5	Yellow(CANL)	CAN L
6	White(+/-)	PAS level

10. Display Printing Code

If customer have requirements, display printing code will obey the requirements.

If customer do not have requirements, display printing code will follow system supplier regulation. Printing code would be

three lines. The first line is the product code and the production date of the display, the second line is the production task list of the display, and the third line is the software name of the display.

Ex: 720523202-1906

039780-0008

D17-HV04-SV7301E-5-L3

11. Q & A

Q: Why I can not power on my display?

A: Check if the battery power on or wire broken.

Q: What could I do if display shows Error Code?

A: Please repair ebike to the retailer or ask King-Meter.

12. Quality commitment and warranty coverage

Warranty Information:

1. For any failure caused by the quality of the product under normal use, the company will be responsible for giving limited warranty during the warranty period.
2. The warranty period of the product is within 30 months after the display leaves the factory.

Out-of-warranty Clause:

1. Unauthorized disassembly and modification
2. Failure or damage caused by misuse or incorrect

installation and debugging by users or third parties.

3. After out of factory, the casing is scratched or damaged.
4. The meter lead wire is scratched or broken
5. Failure or damage caused by force majeure (such as fire, earthquake, etc.) or natural disasters (such as lightning strikes, etc.)
6. The product exceeds the warranty period.

13. Software Version

The version of the display software used on some vehicles may be slightly different from this manual, all subject to actual use version.